

EXP-10SS.DWG

REVISION: U

ECO NO.: 1924-2

DRAWN BY: J. KNOSALLA

DATE: 7/07/03

COXREELS
SERIES P & SH
STAINLESS STEEL

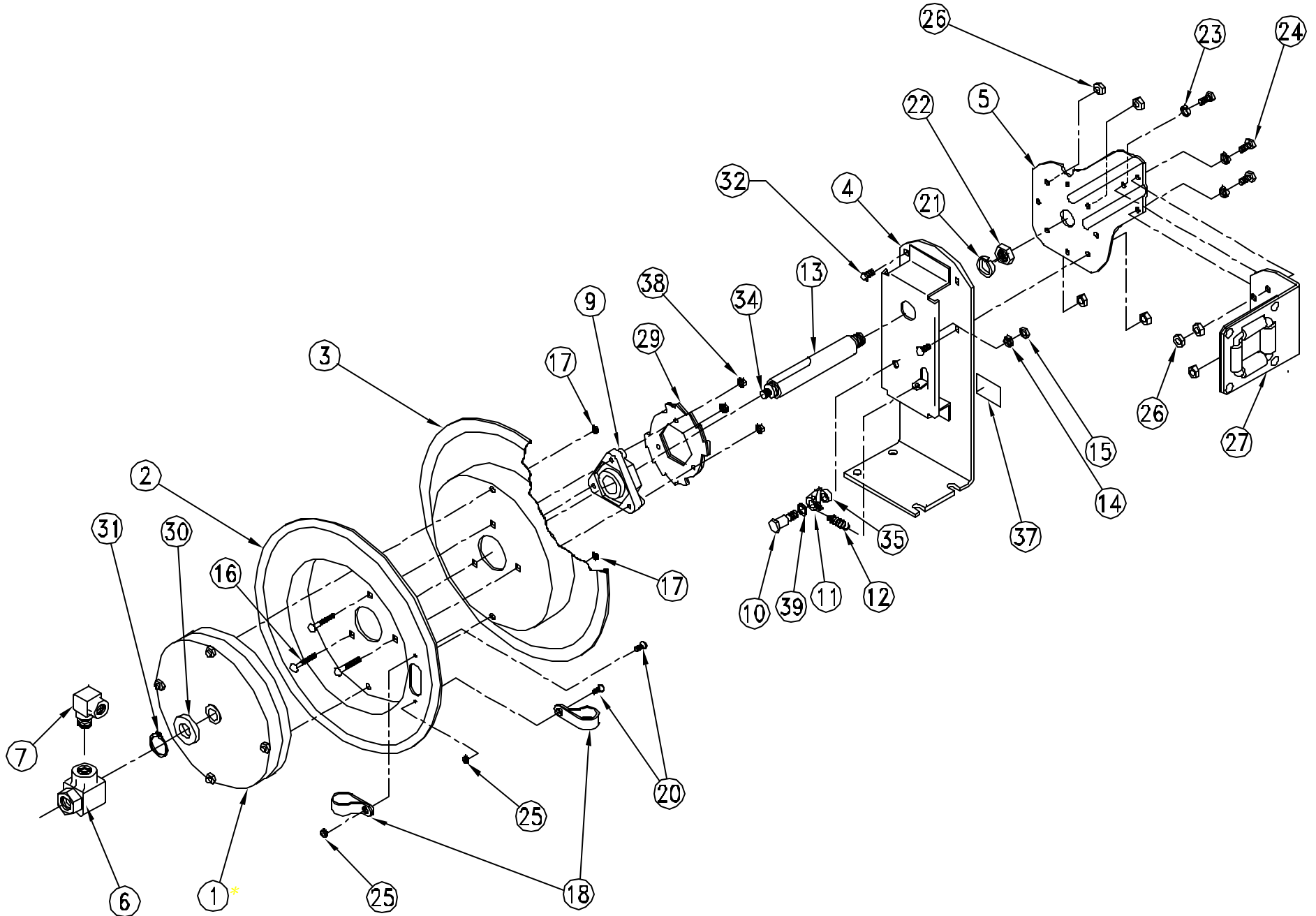

SERIES P, SH, AND MP STAINLESS STEEL REELS

DETAIL ITEM NO.	PART NO.	DESCRIPTION	SHL-N-350-SS	SHL-N-450-SS	SHL-N-525-SS	MPL-N-350-SS	MPL-N-450-SS	P-LPL-335-SS	P-LPL-350-SS	P-LPL-425-SS
1	689-3-SS	SPRING CAN, 10", SS						1		
	689-2-SS	SPRING CAN, 10", SS								1
	1961-7-SS	SPRING CAN, 10", SS							1	
	690-2-SS	SPRING CAN, 12", SS	1							
	691-1-SS	SPRING CAN, 12", SS			1					
	691-3-SS	SPRING CAN, 12", SS		1						
	696-1-SS	SPRING CAN, 12", SS					1			
	646-SS	SPRING CAN, 12", SS				1				
2	1703-SS	DISC, 19-1/2"X 2.25"W, W/SLOT, SS	1	1	1	1	1			
	1948-SS	DISC, 17"X 2.88"W, SS						1	1	1
3	1702-SS	DISC, 19-1/2"X 2.25"W, SS	1	1	1	1	1			
	1947-SS	DISC, 17 X .88", SS						1	1	1
4	1743-2-SS	BASE, 19" REEL, SS	1	1	1	1	1			
	1970-SS	BASE, 17" REEL, SS						1	1	1
5	1732-SS	ARM, GUIDE, SS, 19" REEL	1	1	1	1	1			
	1732-2-SS	ARM, GUIDE, SS, 17" REEL						1	1	1
6	426-SS	SWIVEL, 3/4" NPT, CARBOXYLATED, SS			1					
	433-SS	SWIVEL, 3/8" NPT, CARBOXYLATED, SS	1			1		1	1	
	434-SS	SWIVEL, 1/2" NPT, CARBOXYLATED, SS		1			1			1
7	385-SS	ELBOW, STR, 90DEG, 3/4", SS			1					
9	1776-5	BEARING, HUB, 1" ID	1	1	1	1	1	1	1	1
10	1620-SS	BOLT, SHOULDER, 1/2" X 1-1/2" SS	1	1	1	1	1	1	1	1
11	640-1-SS	LOCKING DOG, F7 REEL, SS	1	1	1	1	1	1	1	1
12	274-1-SS	SPRING, TENSION, LOCKING DOG	1	1	1	1	1	1	1	1
13	1793-SS	AXLE, 1" OD, 1" SPRING CAN, SS	1	1	1	1				
	1794-SS	AXLE, 1" OD, 1-1/2" SPR					1			
	1956-SS	AXLE, 1" OD, 1" SPRING						1	1	1
14	437-SS	WASHER, LOCK 3/8	1	1	1	1	1			
15	435-SS	NUT, LOCK, 3/8-16., 437"	1	1	1	1	1	1	1	1
16	1953-SS	BOLT, CARRIAGE, 1/4-20 X 1-1/2", GR 5, SS	3	3	3	3	3	3	3	3
17	1777-SS	NUT, FLEX-LOCK, 1/4-20, SS	4	4	4	4	4	2	2	2
18	381-SS	CLAMP, HOSE, #10, SS	2			2		2	2	
	382-SS	CLAMP, HOSE, #14, SS		2						2
	383-SS	CLAMP, HOSE, #12, SS					2			
	384-SS	CLAMP, HOSE, #18, SS			2					
20	245-SS	SCREW, 10-32 X 3/8, TRUSS/PHP, SS	2	2	2	2	2	2	2	2
21	438-SS	WASHER, LOCK, 5/8", SS	1	1	1	1	1	1	1	1
22	3584-SS	NUT, HEX, 5/8-11, SS	1	1	1	1	1	1	1	1
23	112-SS	WASHER, LOCK, 5/16", SS	3	3	3	3	3	3	3	3
24	312-SS	BOLT, HEX, 5/16-18 X 3/4", SS	3	3	3	3	3	3	3	3
25	7050-SS	NUT, LOCK, SS, 10-32	2	2	2	2	2	2	2	2
26	111-SS	NUT, LOCK, 5/16-18, SS (LOW PROFILE)	7	7	7	7	7	7	7	7
27	1728-1-SS	ROLLER BRACKET, SS, F7 REEL	1	1	1	1	1			
	1728-3-SS	ROLLER BRACKET, SS, F7 REEL						1	1	1
29	1924-SS	LOCKING RING, SS, F7 REEL	1	1	1	1	1	1	1	1
30	1755-1	WASHER, SPACER, HDPE, BLACK	1	1	1	1	1	1	1	1
31	1753-SS	RETAINING RING, SS	1	1	1	1	1	1	1	1
32	10220-75-SS	BOLT, CARRIAGE, 5/16-18 X 3/4", GR 5, SS	4	4	4	4	4	4	4	4
34	10235-SS	STUD, SS, 3/8-16 UNC-2A X 1	1	1	1	1	1	1	1	1
35	6440-SS	SPACER, WASHER, .286"W., SS	1	1	1	1	1	1	1	1
37	10925-5	NAMEPLATE, PRODUCT, STD DECAL	1	1	1	1	1	1	1	1
38	1777-SS	NUT, FLEX-LOCK, 1/4-20, SS	3	3	3	3	3	3	3	3
39	6441-1	SPACER, WASHER, .050"W., SS	1	1	1	1	1	1	1	1

REEL ASSEMBLY REPORTS

- R100 LATCHOUT REMOVAL PROCEDURE
- R101 LOCKING RING PLACEMENT
- R112 TIGHTENING AND TORQUING